



## ANDMAX D.O.O.

Telefon +381 69 156 12 98  
Email petarkornatovski@gmail.com  
Adresa Ivana Kocija 3 Novi Sad, Srbija

### Dijamantsko tocilo 12A2- 45°

Tabela sa Granulacijom

Namena	Standard Ukrajine ГОСТ 3292-95, мкм	Standard Evrope FEPA
Fino brušenje poliranje	3/5	M4.0
	5/7	M6.3
	7/10	M 10
	14/10	M 16
	20/14	M 16
	28/20	M25
	40/28	M 40
60/40	M 63	
Fino brušenje	50/40	D 46
	63/50	D 54
		D 64
	80/63	D 76
	D 91	
Brušenje	100/80	D 107
	125/100	D 126
		D 151
Grubo brušenje	160/125	D 181
	200/160	D 213
	250/200	D 251
	315/250	D 301
	400/315	D 426

## Skica

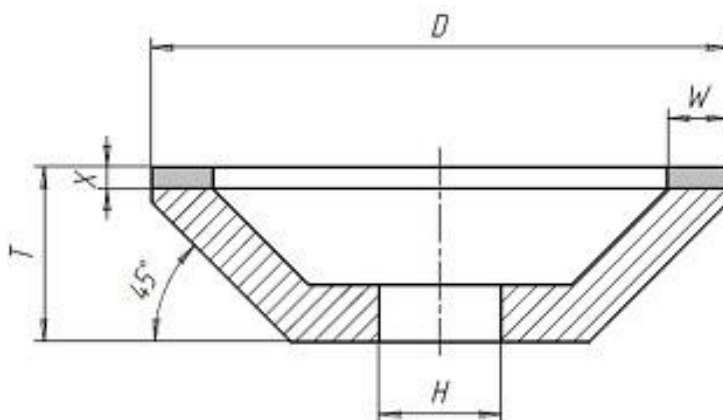

## Tabela dimenzija

D (mm)	T (mm)	W (mm)	X (mm)	H (mm)	Karatnost
50	21	3	2	16	3,9
75	21	6	3	16	17,2
100	32	3	3	20	12,0
100	32	6	3	20	23,4
100	32	10	3	20	37,0
125	40	3	3	32	15,2
125	40	5	3	32	24,9
125	42	5	5	32	41,0
125	25	10	2	20	32,0
125	40	10	3	32	48,0



## ANDMAX D.O.O.

Telefon +381 69 156 12 98  
Email petarkornatovski@gmail.com  
Adresa Ivana Kocija 3 Novi Sad, Srbija

---

150	40	5	3	32	30,0
150	26	6	3	32	36,0
150	40	10	3	32	58,0
150	42	10	5	32	97,0
150	40	20	3	32	108,0
150	42	20	5	32	180,0
150	42	40	5	32	304,0
200	50	10	3	51	79,0
200	50	10	5	51	131,0
200	50	10	5	51	149,0
200	50	20	3	51	149,0

\* Po narudžbini mogu da se naprave i druge dimenzije, kao i veziva i karatnost tocila.

Sve postojeće dimenzije se odnose i na sva CBN tocila i mogu se poručiti na isti način.

Mogu se poručivati i druge dimenzije tocila po vašim merama.